Small universal frequency
converter

Instruction Manual

220V level 0.4 KW - 5.5KW

400V level 0.4 KW - 7.5KW

- Please read this manual carefully and understand the contents for correct installation and use.
- Please hand this instruction to the end user and keep it properly.
- This product technical specification may change without prior notice.

Solemn declaration

Thank you for using frequency converter, before use, must read this instruction carefully, please use after familiar with the safety precautions of this product.

Safety precautions:

Before 1. wiring, please confirm that the input power is off.

2. wiring operation, please professional electrical engineers to carry out.
3. grounding terminal, please be sure to ground.
4. the emergency stop loop wiring is complete, be sure to check that the action is effective.

Do not connect the output line of the 5. frequency converter with the shell, and do not short circuit the output line.

6. please confirm that the voltage of AC main circuit power supply is consistent with the rated voltage of frequency converter.
7. do not carry on the voltage resistance test to the frequency converter.
8. please connect the brake resistance according to the wiring diagram.
9. do not connect the power cord to the output U、V、W terminal.
10. Do not connect the contactor to the output loop.
11. Be sure to install protective cover before power on. When removing the outer cover, be sure to disconnect the power supply.
12. Select the frequency converter with reset test function, do not approach the mechanical equipment. Because the alarm will suddenly start again when it stops.
13. Verify that the operating signal is cut off before alarm reset. Operation signal state alarm reset, frequency converter may suddenly start.
14. Do not touch the terminals of the frequency converter, the terminals

have high voltage, very dangerous.

15. Please do not change the wiring and terminal disassembly.

16. The main circuit is cut off for inspection and maintenance.

17. Do not alter the frequency converter without authorization.

1. technical data

Frequency converter rated data				
Model	Power	Power supply	Output current (A)	Dimensions
				Length*width*high (mm)
G1-220V 0.75	KW 0.75	220 V- 240V single- phase AC 50Hz/60Hz	4	150*115*150
1.5 G1-220V	1.5 KW		7	150*115*150
2.2 G1-220V	2.2 KW		9.5	150*115*150
4.0 G1-220V	4.0 KW		15	210*118*180
G1-220V 5.5	KW 5.5		20	210*118*180
G3-380V 0.75	KW 0.75	370 V- 440V of three- phase communicat ion 50Hz/60Hz	2.5	150*115*150
1.5 G3-380V	1.5 KW		4.1	150*115*150
2.2 G3-380V	2.2 KW		5.8	150*115*150
4.0 G3-380V	4.0 KW		9.4	210*118*180
G3-380V 5.5	KW 5.5		12.6	210*118*180
7.5 G3-380V	7.5 KW		16.1	210*118*180
Type of Brake Resistance				
Model	Power	Input power	Brake resistance power	Brake resistance
G1-220V 0.75	KW 0.75	220 V- 240V single- phase AC 50Hz/60Hz	100W	200 Ω
1.5 G1-220V	1.5 KW		300W	100 Ω
2.2 G1-220V	2.2 KW		300W	100 Ω
4.0 G1-220V	4.0 KW		500W	75 Ω
G1-220V 5.5	KW 5.5		1000W	75 Ω
G3-380V 0.75	KW 0.75	370 V-	100W	750 Ω
1.5 G3-380V	1.5 KW		300W	400 Ω

2.2 G3-380V	2.2 KW	440V of three- phase communication 50Hz/60Hz	300W	250 Ω
4.0 G3-380V	4.0 KW		500W	150 Ω
G3-380V 5.5	KW 5.5		800W	100 Ω
7.5 G3-380V	7.5 KW		1000W	75 Ω

2. installation and wiring

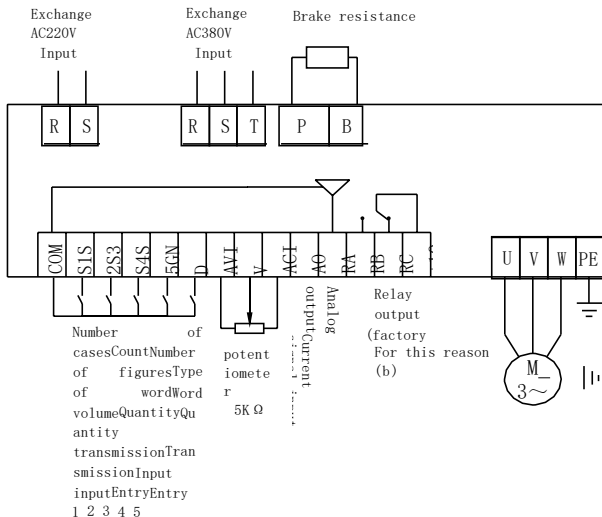

Description of terminal use

Terminal	Purpose	Setting and Description
R, S, T	Inverter Power: R, S, T 380V models 220V type R, S or R, T (according to terminal label)	The front end of inverter input power supply should use air switch as overcurrent protection device. If there is leakage protection switch, in order to prevent leakage switch from misoperation, please select the equipment with sensitivity above 200 mA and

		action time above 100 ms.
U、V、W	Frequency converter output, connected motor	In order to reduce the leakage current, the motor connection line should not exceed 50 meters as far as possible.
P、B	Connect brake resistance	Select brake resistance according to brake resistance selection table.
PE	Ground grounding	Frequency converter should be well grounded.

Terminal	Purpose	Setting and Description
COM	Signal common end	Zero potential of digital signal
S1	Digital input S1	By parameter F2.13 setting, factory default is positive
S2	Digital input S2	By parameter F2.14 setting, factory default is reversal
S3	Digital input S3	By parameter F2.15 setting, the factory defaults to the first position of multi-stage speed
S4	Digital input S4	By parameter F2.16 setting, the factory defaults to the second bit of multi-stage speed
S5	Digital input S5	By parameter F2.17 setting, factory default external reset signal
GND	Signal common end	Zero potential of analog input signal
AVI	0-10 V signal input	0-10 V, Input impedance :>50 k Ω
10V	Frequency setting potentiometer	+10 V, Maximum 10 mA
ACI	4-20 mA analog inputs	mA input impedance 4-20:100 Ω
A0	Analog output signal	By parameter F2.10 setting
RA、RB、RC	Relay output	Set contact capacity F2.20 parameters: AC 250V/3A DC 24V/2A

3. commissioning run

Operation Panel and Operation Methods

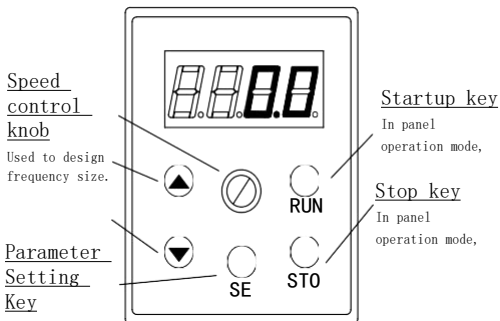

Speed control knob

Used to design frequency size.

Parameter Setting Key

For reading and Parameter values.

Startup key

In panel operation mode,

Stop key

In panel operation mode,

Note: The inverter power up rear panel displays 0.0

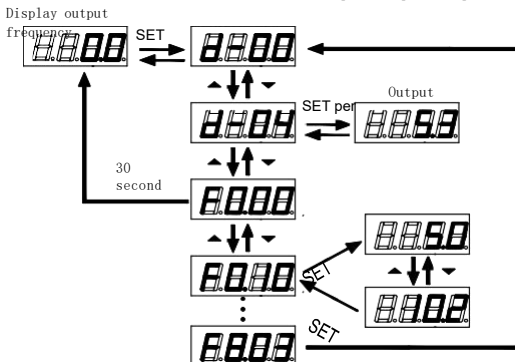

After setting the parameters, return to the original interface method:

After the 1. is cut off, power up again. 2. select the parameter d-00,

then press the SET key. 3. long press SET key

2 inverter operation command mode setting

Frequency converter operation command mode through parameter F0.02 settings: panel control start and stop, and terminal control start and stop two:

(1) Panel control start and stop : (factory set to panel start and stop)

If you want to use the panel to control the start and stop inverter, press the panel green button to start, the red button to stop, the frequency converter default positive start, positive and negative turn through the input terminal S1-S5 settings , (reverse set to 4).

(2) Terminal start and stop:

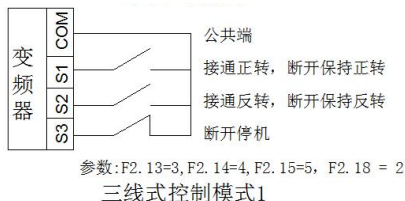
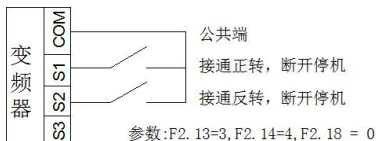

Frequency setting method of 3 frequency

Frequency setting mode of frequency converter is set by parameter F0.03.F0.03=0, The operating frequency is set by a potentiometer; F0.03=3, Operating frequency by AVI input (0-10 V external

potentiometer); At F0.03=5:00, Operating frequency input by ACI (4-20 mA); At F0.03=2, controlled by an external terminal (switch quantity set to frequency increment/decreasing).

4. Parameters

Parameters	Name of name	Ex-factor y value	Scope	Note
Group F0- Basic operating parameters				
F0.0	Frequency converter power	Type	0.1-99.9 kw	Frequency converter current power.
F0.0	Software version	1.0	1.0-99.9	current software version.
F0.0	Run command selection	0	0-1	0: Panel Run Command 1: terminal run command
F0.0	Selection of Frequency Given Mode	0	0-5	0: panel potentiometer input, 1: number given, panel up and down key adjustment Terminal UP/DOWN adjustment 2: given number 3: AVI analog given (0-10 V) 4: combination given (F1.15) 5: ACI given (4~20 mA)
F0.0	Maximum output frequency	50.0 Hz	50.0-999 Hz	The maximum output frequency is the highest frequency allowed by the frequency converter and the benchmark of acceleration and deceleration setting.
F0.0	Upper frequency	50.0 Hz	50.0-999 Hz	The operating frequency shall not exceed that frequency
F0.0	Lower frequency	0.0 Hz	0- Upper limit frequency	The operating frequency shall not be lower than that frequency
F0.0	Lower frequency arrival processing	0	0-2	0: Zero Speed Operation 1: operates at lower frequency 2: downtime
F0.0	Operating Frequency Digital Setting	0	0- Upper limit frequency	The set value is the initial value given by the frequency number

F0.0	Digital Frequency Control	0000	0000~2111	bit: power-down storage 0: storage ,1: do not store ten bits: stop hold 0: hold 1: do not hold 100 bits: UF/DOWN negative frequency regulation 0: invalid 1: valid thousand bits: PID、PLC frequency overlay select 0: invalid 1: F0.03+PID, 2: F0.03+PLC
F0.1	Acceleration time	Type	s 0-255	Time required for frequency converter to accelerate from zero frequency to maximum output frequency
F0.1	Reduction time	Type	s 0-255	Time required for frequency converter to slow down to zero frequency from maximum output frequency
F0.1	Operation direction setting	0	0-2	0: positive turn 1: reverse 2: no reversal
F0.1	V/F curve setting	0	0-2	0: linear curve 1: square curve 2: Multipoint VF Curve

Parameters	Name of name	Ex-factor y value	Scope	Note
F0.14	Torque lift	Type	0.0~30.0%	Manual torque lift, if large torque is required, set to 0.0; this value is set to the percentage of rated voltage relative to the motor.
F0.14	Torque lift cutoff frequency	15.0 Hz	0.0~50.0 Hz	This setting is the lifting cutoff frequency point for manual torque lifting
F0.14	Carrier Frequency Settings	Type	2.0~8.0 KHz	In the case of mute operation, the carrier frequency can be raised to meet the requirements, but increasing the carrier frequency will increase the calorific value of the frequency converter.
F0.14	F1 of V/F frequency values	12.5 Hz	F2~ frequency	
F0.14	V1 V/F voltage values	25.0%	V2~ voltage	
F0.14	F2 of V/F frequency values	25.0 Hz	F3 of frequency F1~ frequency	
F0.20	V2 V/F voltage values	50.0%	Voltage value V1~ voltage value V3 voltage value	
F0.21	F3 of V/F frequency values	37.5 Hz	The frequency value F2~ rated frequency [F4.03] of the motor	

F0.22	V3 V/F voltage values	75.0%	100.0% V2 [^] Machine rated voltage [F4.00]]	
F0.23	User password	0	0~9999	Set any non-zero number and wait 3 minutes or power down to take effect.

Group F1- Auxiliary operating parameters

F1.00	DC braking mode starting	00	0000~0011	Starting mode 0: starting from starting frequency 1: first DC brake and then start from starting frequency 10 bits: blackout or abnormal restart mode 0: invalid ,1 : start from starting frequency 100: reserved, thousands: reserved
F1.01	DC Brake Starting Frequency	1.0 Hz	0.0~50.0 Hz	Frequency to Pre-set Frequency Start DC Brake
F1.02	DC Brake Voltage Starting	0.0%	0.0~50.0% Rated voltage	Voltage value applied for DC braking
F1.03	DC braking time	0.0 s	0.0~30.0 s	Duration of DC braking applied
F1.04	Stop mode	0	0~1	0: deceleration stop ,1: free stop

Parameters	Name of name	Ex-factor y value	Scope	Note
F1.04	Starting frequency of DC brake	0.0 Hz	0.0~ upper limit frequency	Frequency to Pre-set Frequency Start DC Brake
F1.04	Stop DC Brake Voltage	0.0%	0.0~50.0% Rated voltage	Voltage value applied for DC braking
F1.07	Downtime DC braking time	0.0 s	0.0~30.0 s	Duration of DC braking applied
F1.08	Stop DC Brake Waiting Time	0.00 s	0.00~99.99 s	When the braking frequency is reached, the DC braking begins after the delay
F1.09	Frequency setting of positive turning point	10.0 Hz	0.0~50.0 Hz	Set point forward and reverse frequency
F1.10	Frequency setting of reversal point			
F1.11	Point acceleration time	Type	0.1~255.0 s	Set the acceleration and deceleration time
F1.12	Time of point deceleration			
F1.13	Jump frequency	0.0 Hz	0.0~ upper limit frequency	By setting the jump frequency and range, the frequency converter can avoid the mechanical resonance point of the load.
F1.14	Jump range	0.0 Hz	0.0~10.0 Hz	
F1.15	Frequency combination given	0	0~7	0: potentiometer + digital frequency 1 1: potentiometer + digital frequency 2 2: potentiometer +AVI 3: digital frequency 1+AVI 4: digital frequency 2+AVI 5: digital frequency 1+ multi-

				stage 6: digital frequency 2+ multi-stage 7: potentiometer + multi-stage
F1.1	programmable operation control (simple PLC operation)	0000	0000~1221	Bit: PLC enable control 0: invalid, 1: valid ten bits: run mode select 0: single loop, 1: continuous circulation, After 2: single cycle, keep the final value 100 bits: start mode 0: restart from the first stage 1: start at downtime 2: start 1000 bits from the downtime phase, frequency: power-down storage option 0: no storage ,1: storage
F1.1	Multi-speed frequency 1	5.0 Hz	Lower frequency ~ upper limit frequency	Set up segment 1 frequency

Parameters	Name of name	Ex-factor y value	Scope	Note
F1.14	Multi-speed frequency 2	10.0 Hz	Lower frequency ~ upper limit frequency	Set up segment 2 frequency
F1.15	Multi-speed frequency 3	15.0 Hz	Lower frequency ~ upper limit frequency	Set up segment 3 frequency
F1.20	Multi-speed frequency 4	20.0 Hz	Lower frequency ~ upper limit frequency	Set speed 4 frequency
F1.21	Multi-speed frequency 5	25.0 Hz	Lower frequency ~ upper limit frequency	Set up segment 5 frequency
F1.22	Multi-speed frequency 6	37.5 Hz	Lower frequency ~ upper limit frequency	Set speed 6 frequency
F1.23	Multi-speed frequency 7	50.0 Hz	Lower frequency ~ upper limit frequency	Set speed 7 frequency
F1.24	Phase 1 Runtime	10.0 s	0.0~999.9 s	Set the speed 1 run time in units [F1.35] select, default is seconds)
F1.25	Phase 2 Runtime	10.0 s	0.0~999.9 s	Set the speed 2 run time in units [F1.35] select, default is seconds)
F1.26	Phase 3 Runtime	10.0 s	0.0~999.9 s	Set the speed 3 run time in units [F1.35] select, default is seconds)

F1.2	Stage 4 Runtime	10.0 s	0.0~999.9 s	Set the speed 4 run time in units [F1.35] select, default is seconds)
F1.2	Phase 5 Runtime	10.0 s	0.0~999.9 s	Set the speed 5 run time in units [F1.35] select, default is seconds)
F1.2	Phase 6 Runtime	10.0 s	0.0~999.9 s	Set the speed 6 run time in units [F1.35] select, default is seconds)
F1.3	Phase 7 run time	10.0 s	0.0~999.9 s	Set speed 7 operation time in units [F1.35] select, default is seconds)
F1.3	Stage acceleration and deceleration time option 1	0000	0000~1111	Bit: stage 1 acceleration and deceleration time 0~1 10: Stage 2 acceleration/deceleration time ,0~1 100: Stage 3 acceleration/deceleration time 0~1 1000: Stage 4 acceleration/deceleration time ,0~1
F1.3	Stage acceleration and deceleration time 2	000	000~111	Bit: stage 5 acceleration and deceleration time 0~1 10: Stage 6 acceleration/deceleration time ,0~1 100: Stage 7 acceleration/deceleration time 0~1,000: reserved
F1.3	Acceleration time 2	10.0 s	0.1~255.0 s	Set up acceleration and deceleration time 2
F1.3	Reduction time 2			

Parameters	Name of name	Ex-factor y value	Scope	Note
F1.3	Time unit selection	000	000~211	Process PID time unit 10: simple PLC time unit 100: conventional acceleration and deceleration time unit 1000: reserved 0: 1 second 1: 1 point 1: 0.1 seconds
F2 Group - Analog Digital Input and Output Parameters				
F2.0	AVI input lower limit voltage	0.00 V	0.00~ [F2.01]	AVI upper and lower limit voltage
F2.0	AVI input upper limit voltage	V 10.00	[F2.01]~ V 10.00	
F2.0	AVI lower limit corresponds	0.0%	-100.0%~ 100.0%	Set the upper and lower limits of the AVI, which corresponds to the percentage of the upper limit frequency [F0.05].
F2.0	AVI cap setting	100.0%		
F2.0	ACI input lower limit voltage	0.00 mA	0.00~ [F2.05]	Set ACI input upper and lower current
F2.0	ACI input upper limit voltage	m 20.00 A	[F2.04]~ mA 20.00	
F2.0	ACI lower limit corresponds	0.0%	-100.0%~ 100.0%	Set the upper and lower limits of the ACI, which corresponds to the percentage of the upper limit frequency [F0.05].
F2.0	ACI cap setting	100.0%		
F2.0	Filter time constant of analog input signal	0.1 s	0.1~5.0 s	this parameter is used to filter the input signal of the AVI, ACI and panel potentiometer to eliminate the effect of interference.
F2.0	Analog input anti-shake deviation	0.00 V	0.00~0.10 V	when the analog input signal fluctuates frequently near a given value, the frequency

	limit			fluctuation caused by this fluctuation can be suppressed by setting the F2.09.
F2.1	A0 Analog Output Terminal Function Selection	0	0~5	0: output frequency 1: output current 2: motor speed 3: output voltage 4: AVI,5: ACI
F2.1	A0 Output Limit	0.00 V	0.00~ V 10.00	A0 output upper and lower limits
F2.1	A0 Output Limit	V 10.00		
F2.1	Input terminal S1 function	3	0~27	0: control end idle 1: Forward Point Dynamic Control 2: Backward Point Dynamic Control 3: forward control (FWD)
F2.1	Input terminal S2 function	4	0~27	

Parameters	Name of name	Ex-factor y value	Scope	Note
F2.14	Input terminal S3 function	13	0~27	4: reversal control (REV) 5: 3-wire operation control 6: Free Stop Control 7: external stop signal input (STOP)
F2.14	Input terminal S4 function	14	0~27	8: external reset signal input (RST) 9: external fault input 10: frequency increment instruction (UP) 11: Frequency Decreasing Instruction (DOWN)
F2.14	Input terminal S5 function	8	0~27	13: multi-stage speed selection S1 14: multi-stage speed selection S2 15: multi-stage speed selection S3 16: run command channel forces terminal 17: reservations 18: Stop DC Brake Instruction Switch 19: frequency to AVI 20: frequency switched to digital frequency 1 21: frequency switching to digital frequency 2 22: reservations 23: counter zero signal 24: counter trigger signal 25: timer zero signal 26: timer trigger signal 27: acceleration and deceleration time selection
F2.14	FWD/REV terminal control mode	0	0-3	0: 2-wire control mode 1 1: 2-wire control mode 2 2: 3-wire control mode 1 3: 3-wire control mode 2
F2.14	Test of terminal function on power	0	0-1	0: terminal operation command is invalid 1: the terminal operation command is valid

F2.2	Relay R output function setting		0~14	0: idle 1: inverter operational readiness 2: inverter operation 3: inverter running at zero speed 4: external fault shutdown 5: inverter fault 6: frequency/speed arrival signal (FAR) 7: frequency/speed level detection signal (FDT) 8: output frequency reaches upper limit 9: output frequency reaches lower limit 10: Inverter Overload Pre-alarm 11: timer overflow signal 12: counter detection signal 13: counter reset signal 14: Auxiliary Motor
------	---------------------------------	--	------	--

Parameters	Name of name	Ex-factor y value	Scope	Note
F2.2	Reservations			
F2.2	R Closed Delay	0.0 s	0.0~255.0 s	Delay when relay R state changes to output
F2.2	R disconnection delay			
F2.2	Frequency arrival FAR detection amplitude	5.0 Hz	0.0 Hz~ 15.0 Hz	The output frequency is within the positive and negative detection width of the set frequency, and the terminal outputs an effective signal (low level).
F2.2	FDT level setting	10.0 Hz	0.0 Hz~ upper limit frequency	
F2.2	FDT hysteresis	1.0 Hz	0.0~30.0 Hz	
F2.2	UF/DOWN terminal modification rate	1.0 Hz/s	0.1 Hz~ 99.9 Hz/s	Set the frequency modification rate when the UP/DOWN terminal sets the frequency, that is, the UP/DOWN terminal is short connected with the COM terminal for one second, and the frequency changes the size of the quantity.
F2.2	Pulse input trigger setting (S1~S5)	0	0~1	0: means level trigger 1: means pulse trigger
F2.2	Input terminal valid logic setting (S1~S5)	0	0~1	0: means positive logic, that is, Si terminal is connected with common end effectively, disconnect invalid 1: indicates inverse logic, that is, Si terminal is connected with common end invalid, disconnect valid
F2.3	S1 filter coefficients	5	0~9999	used to set the sensitivity of

F2.3	S2 filter coefficients	5	0~9999	the input terminal. If the digital input terminal is vulnerable to interference and causes misoperation, the parameter can be increased, then the anti-interference ability will be enhanced, but the sensitivity of the input terminal will be reduced. 1: represents 2 MS scanning time units
F2.3	S3 filter coefficients	5	0~9999	
F2.3	S4 filter coefficients	5	0~9999	
F2.3	S5 filter coefficients	5	0~9999	

F3 group - PID parameter settings

F3.0	PID function settings	1010	0000~2122	<p>Position: PID adjustment characteristic 0: invalid 1: negative feedback 2: positive feedback 10: PID to quantitative input channel 0: keyboard potentiometer 1: number given</p> <p>The PID given quantity is given by the number and set by the function code F3.01.</p> <p>2: pressure given (MPa, Kg) by setting F3.01、F3.18 given pressure. 100 bits: FID feedback input channel 0: AVI, 1: ACI Thousand bits: PID sleep selection 0: invalid 1: ordinary sleep, this way needs to set F3.10~F3.13 and other specific parameters. 2: disturbance sleep</p>
------	-----------------------	------	-----------	---

Parameters	Name of name	Ex-factor y value	Scope	Note
				The parameter setting is the same as when the sleep mode selects 0. If the PID feedback value is within the range of the F3.14 set value, the sleep delay time is maintained and the disturbed sleep is entered. Feedback value less than recovery threshold (PID polarity is positive) wake up immediately
F3.0	Setting quantitative figures	0.0%	0.0~100.0%	The keyboard is used to set the given quantity of PID control. Only when the number is given PID the given channel (F3.00 10 bits is 1), this function is effective.
F3.0	Feedback Channel Gain	1.00	0.01~10.00	When the feedback channel is inconsistent with the set channel level, this function can adjust the gain of the feedback channel signal.
F3.0	P of proportional gain	1.00	0.01~5.00	PID the speed of adjusting speed is set by the two parameters of proportional gain and integral time. It is necessary to increase the proportional gain and reduce the integral time, and to reduce the proportional gain and the integral time. In general, differential time is not set.
F3.0	Ti of integral time	2.0 s	0.1~50.0 s	
F3.0	Td of differential time	0.0 s	0.1~10.0 s	
F3.0	T sampling period	0.0 s	0.1~10.0 s	The larger the sampling period, the slower the response, but the better the suppression effect on the interference signal, generally no

F3.0	Deviation limits	0.0%	0.0~20.0%	Deviation limit is the ratio of the absolute value of the deviation between the system feedback quantity and the given quantity. When the feedback quantity is within the deviation limit, the PID does not adjust
F3.0	Closed-loop preset frequency	0.0 Hz	0.0~ upper limit frequency	Frequency and running time of frequency converter before PID put into operation
F3.0	Preset frequency hold time	0.0 s	0.0~999.9 s	
F3.1	Wake-up threshold factor	100.0 %	0.0~150.0%	When the actual feedback value is greater than the set value and the frequency output of the frequency converter reaches the lower limit frequency, the frequency converter enters the sleep state (i.e. zero speed operation) after value is the percentage of the PID set value) after the delay waiting time defined by the frequency converter
F3.1	Recovery threshold factor	90.0%	0.0~150.0%	When the feedback value is less than the set value, the inverter starts to work after the delay wait defined by the F3.13, which is the percentage of the PID set value.
F3.1	Sleep delay	100.0 s	0.0~999.9 s	Setting Sleep Delay Time
F3.1	Recovery delay	1.0 s	0.0~999.9 s	Set the time of wake delay
F3.1	Feedback and set pressure deviation when entering sleep	0.5%	0.0~10.0%	This function parameter is only valid for disturbed sleep mode

Parameters	Name of name	Ex-factor value	Scope	Note
F3.14	Detonation delay	30.0	0.0~999.9 s	Set Detecting Delay Time
F3.14	High pressure detection threshold	150.0%	0.0~200.0%	When the feedback pressure is greater than or equal to this set value, the tube burst fault "is reported after the delay of the F3.15 tube burst EPA0", when the feedback pressure is less than this set value" EPA0" automatically reset; the threshold value is the percentage of the given pressure.
F3.14	Low pressure detection threshold	50.0%	0.0~200.0%	When the feedback pressure is less than this set value, the tube burst fault is reported after the delay of the F3.15 tube burst "EPA0", when the feedback pressure is greater than or equal to this set value, the tube burst fault" is automatically reset; the threshold value is the percentage of the given pressure.
F3.14	Sensor Range	10.0 MPa	0.00~99.99 (MPa, Kg)	Set the maximum range of sensors

Group F4- Advanced Functional Parameters

F4.04	Rated voltage	Type	0~500 V	Motor parameter setting
F4.04	Rated Current	Type	0.1~999.9 A	
F4.04	Rated speed	Type	0~60000 Krpm	
F4.04	Rated frequency	50.0 Hz	1.0~999.9 Hz	

F4.0	Stator resistance	Type	0.001~ 20.000 Ω	Set motor stator resistance
F4.0	No-load current	Type	0.1~ [F4.01]	Set up motor no-load current
F4.0	AVR function	0	0~2	0: invalid, 1: valid throughout 2: is invalid when decelerating only
F4.0	Reservations	0	-	Reservations
F4.0	Automatic resetting of faults	0	0~10	When the reset number is set to 0, there is no automatic reset function, only manual reset 10 indicates that the number of times is not limited, that is, countless times.
F4.0	Fault automatic reset interval	3.0 s	0.5~25.0 s	Setting fault auto reset interval
Group F5- Protection function parameters				
F5.0	Protection settings	0001	0000~1211	Motor overload protection option 0: invalid 1: effective 10: PII feedback break protection 0: invalid 1: protection action and free shutdown

Parameters	Name of name	Ex-factor y value	Scope	Note
				100: Keep 1000: Oscillation suppression option 0: invalid 1: effective
F5.0	Motor overload protection factor	100%	30%~110%	The motor overload protection coefficient is the percentage of the rated current value of the motor to the rated output current value of the inverter.
F5.0	Under pressure protection level	180/360V	150-280 300~480 V	This function code specifies the lower limit voltage allowed by DC bus when the frequency converter is working normally.
F5.0	Reduction Voltage Limit Factor	1	0: off, 1~255	This parameter is used to adjust the ability of frequency converter to suppress overvoltage during deceleration.
F5.0	Overpressure Limit Level	375/790V	350-380 660~760 V	Over-voltage limit level defines the operating voltage of over-voltage stall protection
F5.0	Accelerated current limiting factor	125	0: off, 1~255	this parameter is used to regulate the ability of the inverter to suppress overcurrent during acceleration.
F5.0	Constant current limiting factor	0	0: off, 1~255	This parameter is used to adjust the ability of frequency converter to suppress overcurrent in constant speed process.
F5.0	Current Limit Level	200%	100%~ 250%	The current limit level defines the current threshold for automatic current limiting action, which is the percentage of the rated current relative to the frequency converter.
F5.0	Feedback breakage detection	0.0%	0.0~100.0%	This value is the percentage given by the PID. When the PID feedback value is continuously less than the feedback break detection value, the frequency

				converter will make the corresponding protection action according to the F5.00 setting, which is invalid when the F5.08 is 0.0.
F5.00	Feedback Break Detection Time	10.0 s	0.1~999.9 s	After the feedback break occurs, the delay time before the protection action.
F5.10	Frequency converter overload pre-alarm level	120%	120~150%	The current threshold of the inverter overload pre-alarm action, whose set value is the percentage of the rated current relative to the frequency converter.
F5.11	Frequency converter overload pre-alarm delay	5.0 s	0.0~15.0 s	Frequency converter output current from continuous greater than overload pre-alarm level amplitude (F5.10), to output overload pre-alarm signal delay time.
F5.12	Point priority enable	0	0~1	0: invalid 1: frequency converter operation, the highest priority of point motion
F5.13	Oscillation suppression coefficient	30	0~200	When the motor shock occurs, it is necessary to set up F5.00 thousand effective, open the shock suppression function, and then adjust by setting the shock suppression coefficient. In general, the oscillation amplitude is large, increase the shock suppression coefficient F5.13, F5.14~F5.16 do not need to be set; if you encounter a special occasion, Need to F5.13F5.13, F5.14~F5.16F5.16 together to use.
F5.14	Amplitude suppression coefficient	5	0~12	
F5.15	Lower limit frequency of oscillation suppression	5.0 Hz	0.0~ [F5.16]	
F5.16	Oscillation suppression upper limit frequency	45.0 Hz	[F5.15]~ [F0.05]	

Parameters	Name of name	Ex-factor y value	Scope	Note
F5.1	Wave-by-wave limiting flow selection	011	000~111	Select 0 in acceleration: invalid 1: valid 10: select 0 in deceleration: invalid 1: valid 100: constant speed 0: invalid ,1: valid thousand: reservation
Group F6- Communication parameters (reserved)				
Group F7- Supplementary functional parameters				
F7.0	Counting and timing mode	103	000~303	Bit: Count to Process ,0: Weekly Count Number, stop output 1: single cycle count, continue output 2: cycle count, stop output 3: cycle count, continue output. Ten: Reservations 100 bits: Time-to-time ,0: Weekly Stop output 1: one week timing, continue output 2: cycle timing, stop output 3: cycle timing, continue output. Thousands: reserved
F7.0	counter reset value setting	1	[F7.02]^9999	Set counter reset value
F7.0	Counter detection value setting	1	~[F7.01]]0	Set counter detection value
F7.0	Timing time setting	s 0	~9999 s	Set timing time
F8 Group - Managing and Display Parameters				
F8.0	Operational monitoring parameters	0	0~26	The default display item of the main monitoring interface. Corresponding numbers are d set of parameters.
F8.0	Stop	1	0~26	The default display item of the main monitoring interface.

	monitoring parameters			Corresponding numbers are d set of parameters.
F8.0	Motor speed display coefficient	1.00	0.01~99.99	It is used to correct the error of speed scale display and has no effect on actual speed.
F8.0	Parameter initialization	0	0~2	0: no operation 1: Restoring Factory Setting User parameters according to the model to restore the factory set value. 2: troubleshooting records
Group F9- manufacturer parameters				
F9.0	Manufacturer's password		1-9999	System setup private password
F9.0	Model selection	1	0-14	220V: 0: 0.4KW 1: 0.75KW 2: 1.5 KW 3: 2.2KW 4: 4.0KW 5:

Parameters	Name of name	Ex-factor y value	Scope	Note
				KW 6: 7.5KW 5.5 380V: 7: 0.4KW 8: 0.75KW 9: 1.5 KW 10: 2.2KW 11:3.0 KW 12: 4.0KW 13: 5.5KW 14.5 KW
F9.04	Dead zone time	Type	2.5~4.0 μS	2.5~4.0 μS 0.4~4.0 KW.....2.8 us 5.5 KW~22 KW.....us 3.2
F9.03	Software overvoltage detection value	400/810V	V/900V 0-450	Over-voltage detection threshold
F9.04	Voltage correction factor	1.00	0.80~1.20	Bus voltage values for calibration testing
F9.04	Current correction factor	1.00	0.80~1.20	Current value for calibration testing
F9.06 ~F9.09	Reservations	0		Reservations
F9.10	Special function selection	Type	0-2	Bit: cumulative run time zero option 0: invalid 1: valid 10: Type 0: General Model (G), 1: Light Load (F), 2: Heavy duty (Z) 100 bits: reserved. Thousand: reserved.

d Group - Monitoring Parameter Group

Parameters	Name of name	Scope	Minimum units
d-00	Output frequency (Hz)	0.0~999.9 Hz	0.1 Hz
d-01	Frequency (Hz)	0.0~999.9 Hz	0.1 Hz

d-02	Output voltage (V)	0~999 V	1V
d-03	Bus voltage (V)	0~999 V	1V
d-04	Output current (A)	0.0~999.9 A	0.1 A
d-05	Motor speed (Krpm)	0~60000 Krpm	1Krpm
d-06	Analog input AVI (V)	0.00~10.00 V	0.01 V
d-07	Analog input ACI (mA)	0.00~ mA 20.00	0.01 mA
d-08	Analog output AO (V)	0.00~10.00 V	0.01 V
d-09	Reservations	-	-
d-10	Reservations	-	-

d-11	PID pressure feedback values	0.00~10.00 V/ 0.00~99.99 (MPa、) Fiscal year :2003 Kg)	0.01 V/(MPA), Kg)
d-12	Current count value	0~9999	s 1
d-13	Current timing value (s)	~9999 s	s 1
d-14	Input terminal status (S1-S5)	0~1 FH	1H
d-15	Output relay status (R)	0~1 H	1H
d-16	Reservations	Reservations	-
d-17	Software upgrade date (year)	2010~2026	1
d-18	Software upgrade date (month, day)	0~1231	1
d-19	Second failure code	0~19	1
d-20	Last failure code	0~19	1
d-21	Frequency of output (Hz) during the last failure	0.0~999.9 Hz	0.1 Hz
d-22	Output current at last fault (A)	0.0~999.9 A	0.1 A
d-23	Bus voltage (V) at last fault	0~999 V	1V
d-24	Reservations	Reservations	-
d-25	Frequency converter operation cumulative time (h)	~9999 h	h 1

E Group - Fault Code			
Fault Code	Name of name	Possible causes of failure	Fault Countermeasures
EOC1	Overflow in accelerated operation	The acceleration time is too short	Extension of acceleration time
		Low frequency converter power	Select high power frequency converter
		Improper setting of V/F curve or torque lift	Adjust V/F curve or torque increase
EOC2	Overflow during	Slow down too short	Extended deceleration
		Low frequency converter	Select high power

	deceleration	power	frequency converter
EOC3	Overflow in uniform speed	Low grid voltage	Check input power
		Mutation or abnormality of load	Check load and reduce load mutation
		Low frequency converter power	Select high power frequency converter
EHU1	Overpressure in accelerated operation	Abnormal input voltage	Check input power
		Restart the rotating motor	Set to start after DC braking
EHU2	Slow down operation	Slow down too short	Extended deceleration

	Medium Overpressure	Abnormal input voltage	Check input power
EHU3	Overpressure in uniform speed	Abnormal input voltage	Check input power
EHU4	Over-voltage during downtime	Abnormal input voltage	Check supply voltage
ELU0	Underpressure in operation	Abnormal input voltage or unabsorbed relay	Check supply voltage or seek service from manufacturer
ESC1	Power module failure	Frequency converter output short circuit or ground	Check motor wiring
		Frequency converter transient overcurrent	See Overflow Countermeasures
		Abnormal control panel or serious disturbance	Seek services from manufacturers
		Damage to power devices	Seek services from manufacturers
EOL1	Frequency converter overload	Improper setting of V/F curve or torque lift	Adjust V/F curves and torque increases
		Overflow voltage grid	Check grid voltage
		The acceleration time is too short	Extension of acceleration time
		Motor overload	Select a higher power frequency converter
EOL2	Motor overload	Improper setting of V/F curve or torque lift	Adjust V/F curves and torque increases
		Overflow voltage grid	Check grid voltage
		Excessive motor shutoff or load mutation	Check the load
		Improper setting of motor overload protection factor	Correctly set up motor overload protection factor

E-EF	External equipment failures	External fault input terminal closed	Disconnect external equipment fault input terminal and clear fault (note check cause)
EPID	PID feedback breakage	PID feedback lines loose	Check the feedback link
		The feedback is less than the detection value	Adjust test input threshold
ECCF	Current detection fault	Fault of Current Sampling Circuit	Seek services from manufacturers
		Auxiliary power failure	
EEEP	EEPROM Read and write errors	EEPROM fault	Seek services from manufacturers
EPAO	Explosive tube failure	Feedback pressure less than or greater than the low pressure test threshold	Check feedback line and adjust high and low pressure threshold
EPOF	Dual CPU Communication Fault	CPU communication failures	Seek services from manufacturers

5. Application Examples

(1) Constant Pressure Water Supply Control

A: contact pressure gauge control (simplest control mode)

Use the electrical contact pressure gauge to control the water pressure, only need to connect 2 wires, one from the green needle, one to come From the black needle, respectively connected to the three connection posts of the electrical contact pressure gauge on the top 2 (some electrical contact gauges may be different). When the water is low, the black needle is under the green needle, the frequency converter is in the accelerated start state, the black needle is above the green needle when the water pressure is high, and the frequency converter is in the state of deceleration and shutdown. very simple and easy to maintain.

For the inverter, the debugging steps are as follows:

One line from the electrical contact pressure gauge is connected to the S1 and the other line to the COM (no need to distinguish between positive and negative, please connect the start signal after setting all the parameters).

2 Set parameter F0.02=1 Select external terminal start control.

Adjust the speed control knob on the panel to the maximum.

The frequency converter parameter setting: F2.13=3 (default value), F0.10F2.13=60, F0.11F2.13=60, F2.19F2.13=1 power on can start automatically. You can connect the S1 and COM, directly to see if it starts

Move, if still can not start, explain is frequency converter internal setting problem. If you can start, it is an external electrical contact list or line problem, you can check whether the two lines on the electrical contact are on, the black needle should be on below the green needle, and the black needle should be disconnected above the green needle.

B: PID constant pressure water supply control (AVI given)

The PID control is carried out by using the built-in PID control

function of the frequency converter, and the pressure sensor or remote pressure gauge is used for water pressure collection.

Debugging steps:

Connect the remote pressure gauge water pressure signal to the GND、AVI、10V. If it is a 2-wire pressure sensor, it is connected to the GND、AVI. A remote pressure gauge voltage feedback value can be seen in the parameter d-06.

2 Parameter settings:

If the panel is used to start, set the parameter F0.02=0.

When the external terminal is used to start, set the parameters F0.02=1, F2.13F0.02=3(default value), and the F2.19F0.02=1 start signal line is connected to the S1 and COM (all parameters are modified to connect the start line).

F0.10=30, F0.11F0.10=30 acceleration and deceleration time can be adjusted according to practical application

F3.00=1011, PID negative feedback, feedback signal AVI given, PID given by the quantitative given. F3.01, used to set the size of the water pressure, the setting range is 0-100, through which the water pressure is adjusted

High and low (0-10 V corresponding pressure gauge range). Can be adjusted to 20, according to the actual application and then adjust the size.

③PID control the speed of regulation:

F3.03=1.00(default value), P value parameter adjustment, the larger the P value, the faster the adjustment speed.

F3.04=2.0(default value), I value parameter adjustment, the larger the I value, the slower the adjustment speed.

(2) Two Speed Given Mode Control

Equipment requirements: positive turn using potentiometer knob speed regulation, reverse using multi-speed low-speed operation.

Parameter settings: F0.02=1, F0.03F0.02=3, F1.17F0.02=10(reverse speed 10 HZ)

Wiring: potentiometer 3 wires connected to GND 、 AVI 、 +10 V, The forward signal is attached to the S1 and COM, A reverse signal is connected to S2、 COM, Short connection of S2 and S3(set frequency at the same time to select the setting value of multi-segment speed 1).

(3) Point movement control

Equipment requiring point control:

Parameter setting: F0.02=1, F2.15F0.02=1(positive point), F2.16F0.02=2(reverse point), positive point frequency is given by parameter F1.09, reverse point frequency is given by parameter. The point acceleration time is set by the parameter F1.11, and the point deceleration time is set by the parameter F1.12.

Wiring: the forward point signal is connected to the COM and S3, and the reverse point is connected to the COM and S4.

(4) Low speed running torque is insufficient (rotation is boring)

Adjustment parameters F0.14, from small to large step by step adjustment, do not adjust too large at the beginning, adjustment is likely to report OC overcurrent fault.

Adjust the parameter F0.15, which is the frequency of torque lifting cutoff.

(5) Application in Vijonka engraving machine

When used on a Vijonka engraving machine,

Wiring: There will be 4 wires on the Vihong card, which are:
common line, low speed line, medium speed line, high speed line.

These four wires are respectively connected to the COM, S3, S4, S5 of the frequency converter.

2 Parameter settings: F0.02=1, F0.04=400(based on motor nameplate), F0.05=400(based on motor nameplate), F1.17=100, F1.18=150, F1.19=200, F1.20=250, F1.21=300, F1.22=350, F1.23=400, F2.17=15, F2.19=1.

F4.03=400(motor rated frequency, set according to motor nameplate).

The terminal COM and S1. are connected by wire after power off
Then power on (note: the spindle may rotate after power on, to ensure safety).

Service transfer value, quality cast brilliant

To inform users:

Thank you for using our products. In order to ensure that you get the best after-sales service, please read the following terms carefully and do a good job.

1. product warranty scope

Any failure in normal use as required is within the scope of warranty.

2. product warranty period

The warranty period of this product is within 12 months from the date of departure. Implement long-term technical support service after warranty period.

3. non-warranty scope

Any damage caused by human factors, natural disasters or water intake, external force damage, bad environment, etc., in violation of the use requirements, as well as the unauthorized disassembly, modification and maintenance of the frequency converter, shall be deemed to be an automatic abandonment of warranty service.

4. buy products from intermediaries

All users who buy products from dealers, agents, in case of product failure, please contact the dealer or agent.

Please keep this manual properly for use when necessary.



2017 Year 5 Month completed
to WeChat Public

Technical support